



Extractor Industrial Axial

CARACTERÍSTICAS

- Motor sellado con rodamiento a bolas.
- Alto caudal.
- Pintura epóxica.
- Hélice con alineación y balances.

USOS

Galeras, talleres, cuartos de pintura, fábricas, locales deportivos.

Extractor Industrial Axial

Modelo	Velocidad RPM	Potencia W	Tensión Volts	Caudal a descarga libre / CFM	Cantidad por caja	Peso aprox. por caja kg
APK25-5	1400	40W	110	432 CFM	6	13.8
FAC-30	1400	130W	110	1130 CFM	1	9.8
FAC-40	1400	220W	110	2400 CFM	1	11.4
FAC-45	1400	380W	110	3530 CFM	1	16.9
FAC-60	1400	380W	110	4030 CFM	1	27

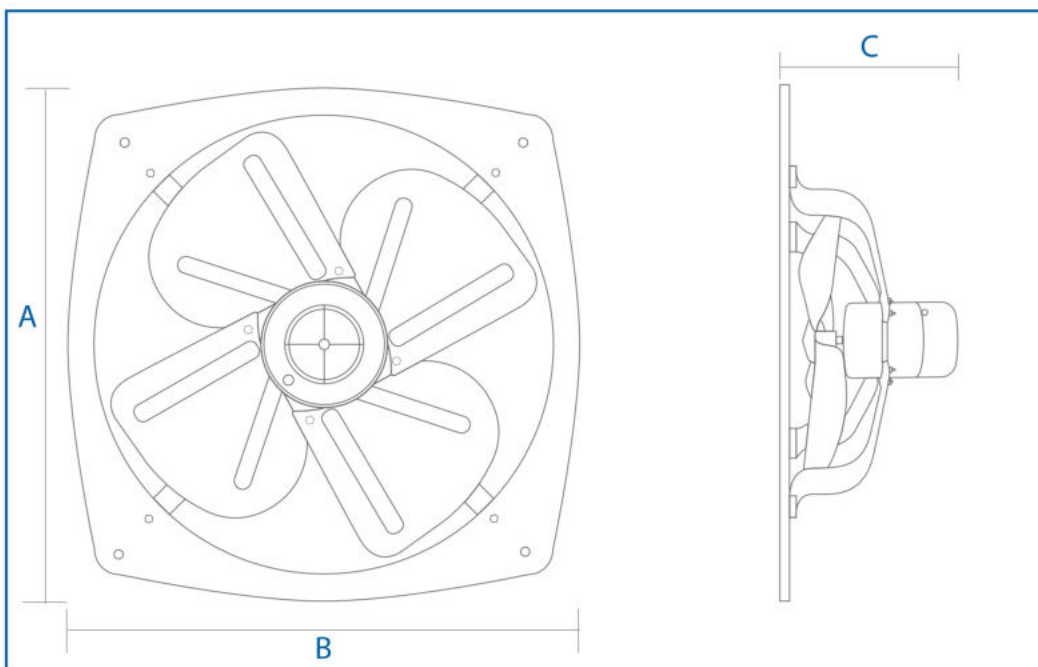

	APK25-5	FAC-30	FAC-40	FAC-45	FAC-60
A	11 1/16	15 1/4	19	22	28 3/8
B	11 1/16	15 1/4	19	22	28 3/8
C	5 5/8	9 7/16	10 1/16	11 1/4	13 1/4
Hélice	10"Ø	12"Ø	16"Ø	18"Ø	24"Ø